

iRobotCAM

INTELLIGENT COMPUTER AIDED MANUFACTURING FOR ROBOTICS



Outline

1 Company Introduction 03

- Brief Introduction

2 Product Introduction 05

- Product Architecture
- Product Advantage
- Product Functions

3 Customers 10

- Numerical Control Equipment
- Special Equipment Integration
- Education Equipment



01 COMPANY
INTRODUCTION

Brief

Yueqing Technology was founded in 2020 and located in Nanjing, JianSu Province.

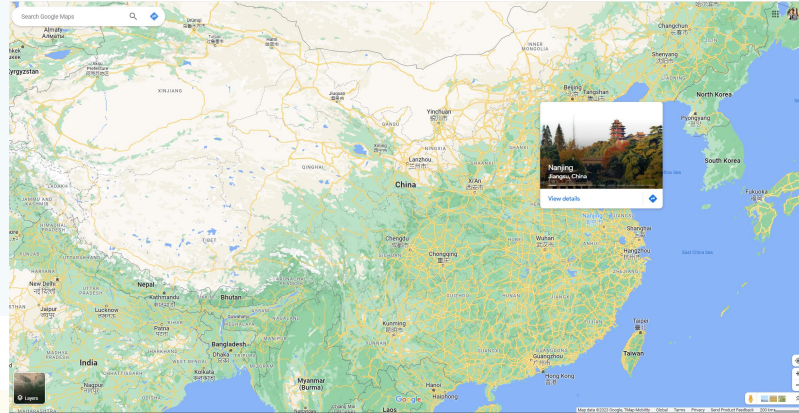

Team

Dedicated in developing the digital robot machining platform

Focus on mechatronics concept design, robot machining simulation, and virtual debugging.

History

- 2020 Yueqing Technology was founded, started the development for iRobotCAM, with the collaboration with SouthEast University.
- 2021 iRobotCAM Preview was released, started to collaborate with ZWSOFT.
- 2022 Started Mechatronics design module and process simulation and collaborate with GSK.
- 2023 iRobotCAM V1.0 was officially released.

02 PRODUCT INTRODUCTION

iRobotCAM Product architecture

Application Level	Platform Level	Core Engine
Welding Spraying Virtual debuggin Additive machining Assembly simulation	iRobotCAM Digital Machining Platform	Geometry Modeling Phisical motion engine Robot Tragetory Algorithm Robot motion simulation

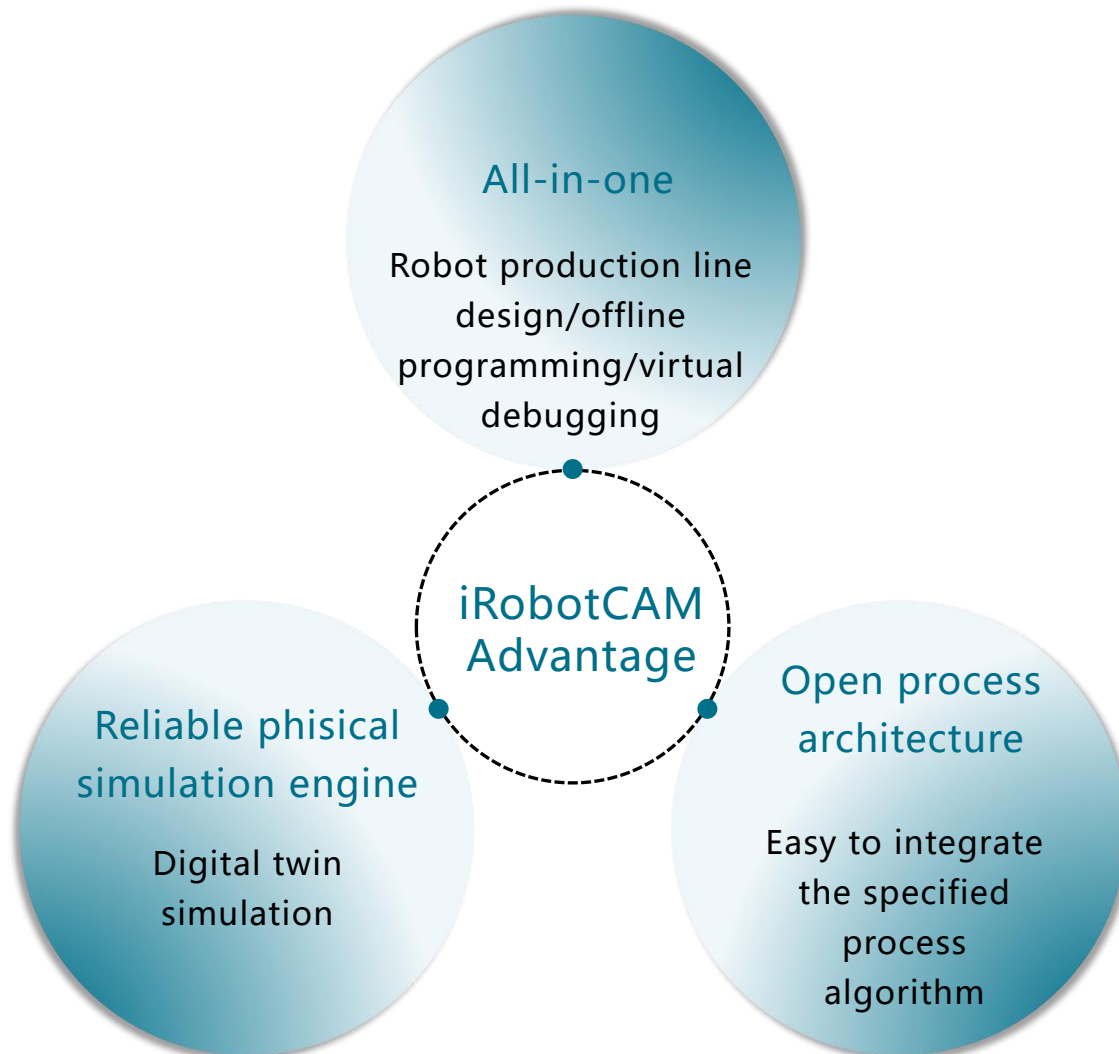

iRobotCAM Functions

Robot production line design

With the parametric design capability to fulfill the robot workstation or production line design

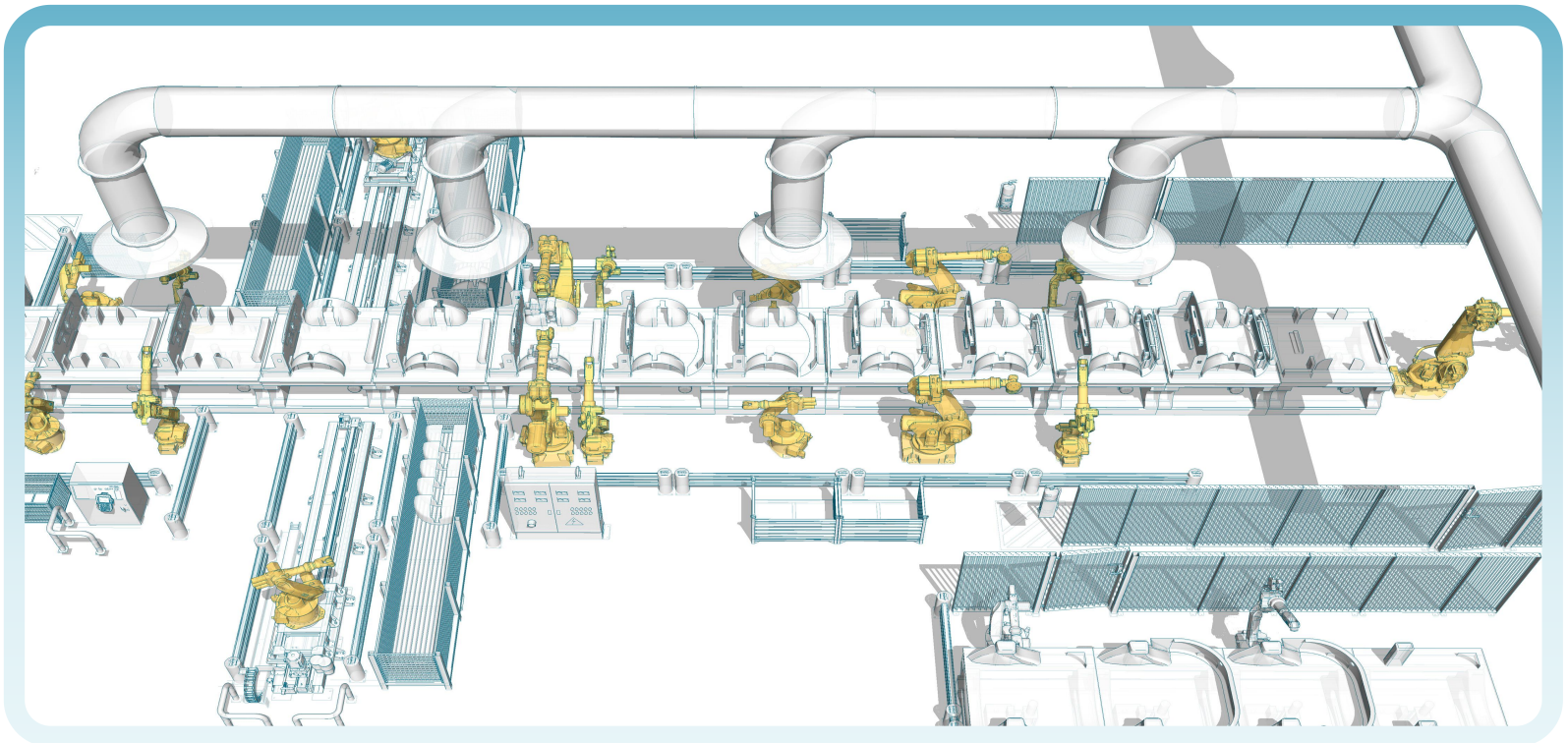

Robot offline programming

programming process:
 Robot import--> process
 planning--> machining
 simulation--> workstation
 optimization--> posting

verification:
 program decompilation,
 verification and
 optimization

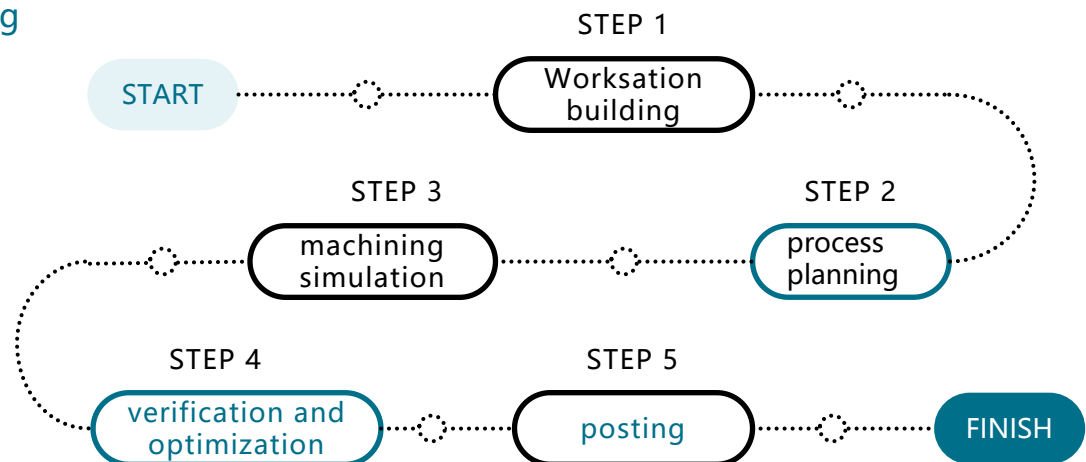

iRobotCAM Functions

Robot offline programming

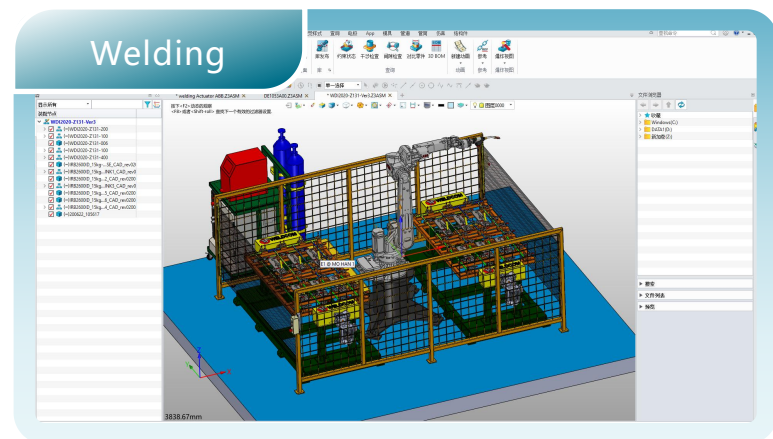
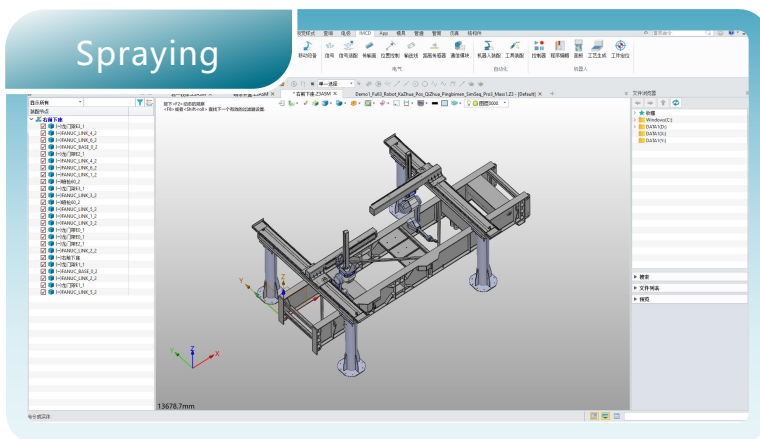
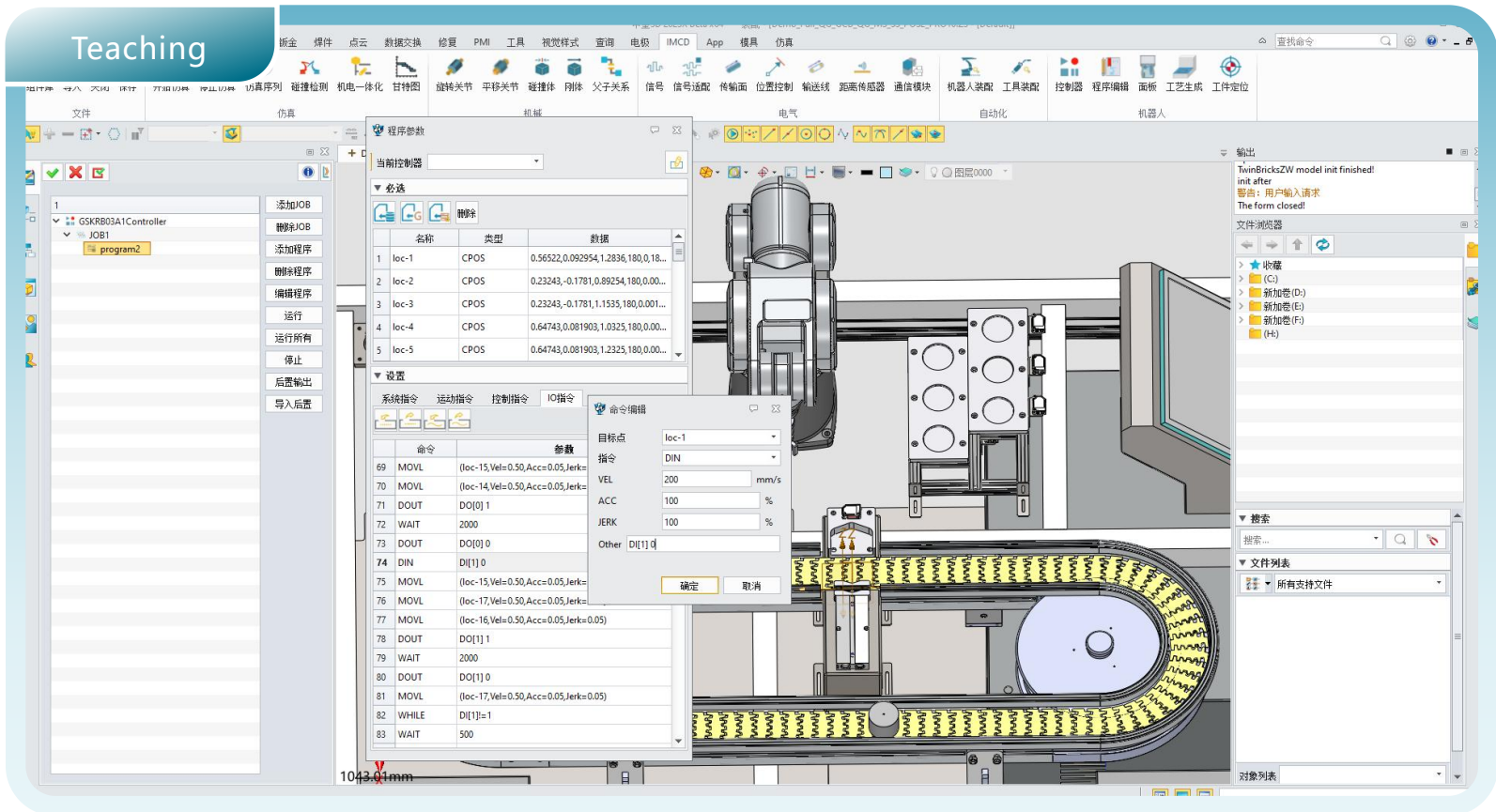

iRobotCAM Functions

Virtual debugging

virtual debugging and virtual monitoring by digital-twin; supports multi-machine IO communication simulation, multi-robot synchronization, and multi-axis linkage planning of robots.

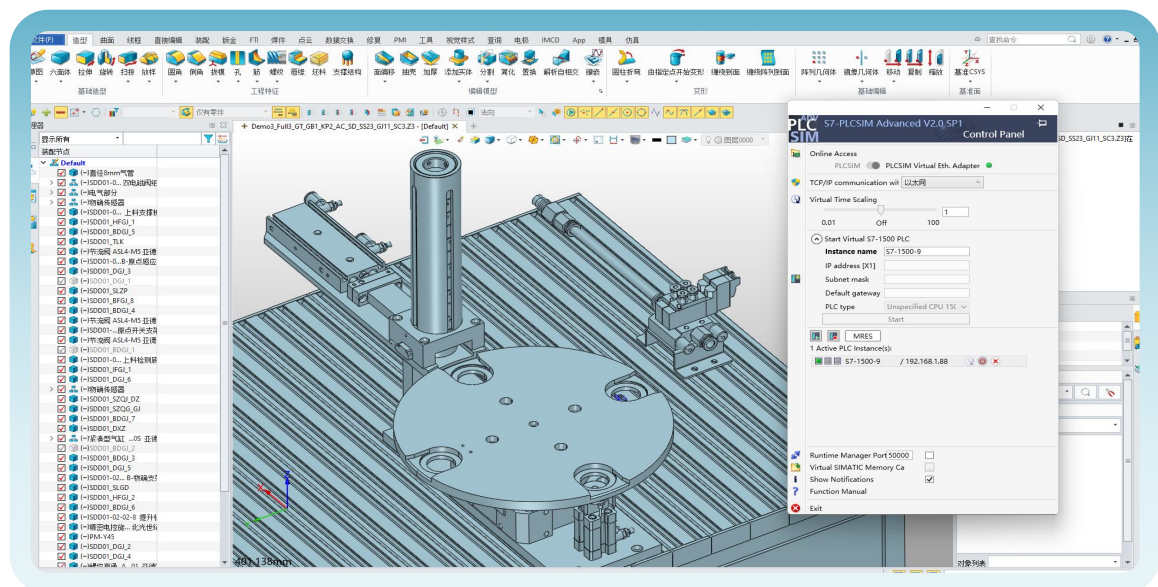
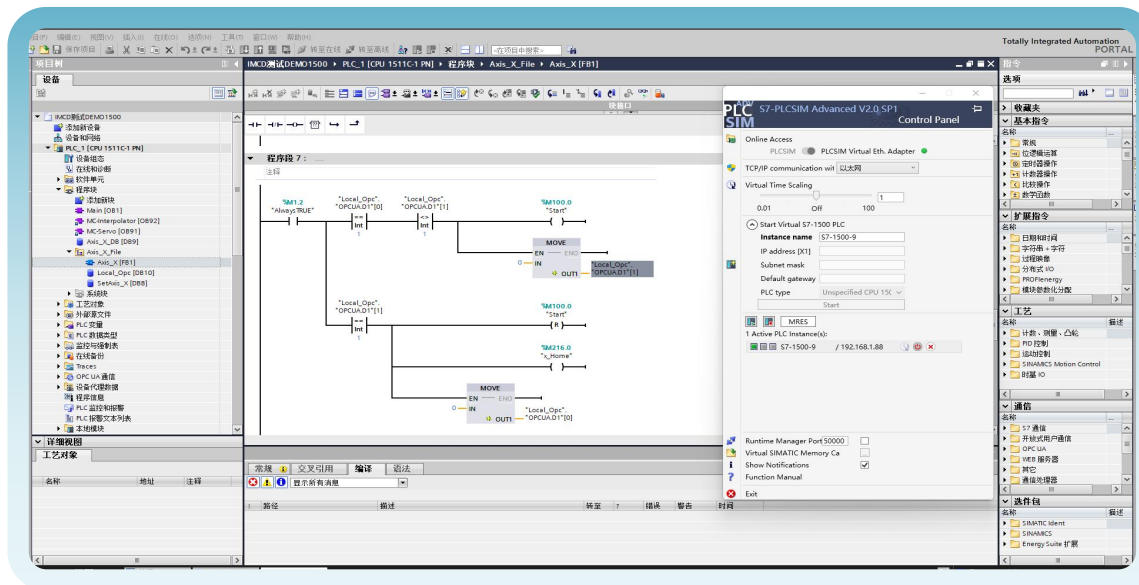

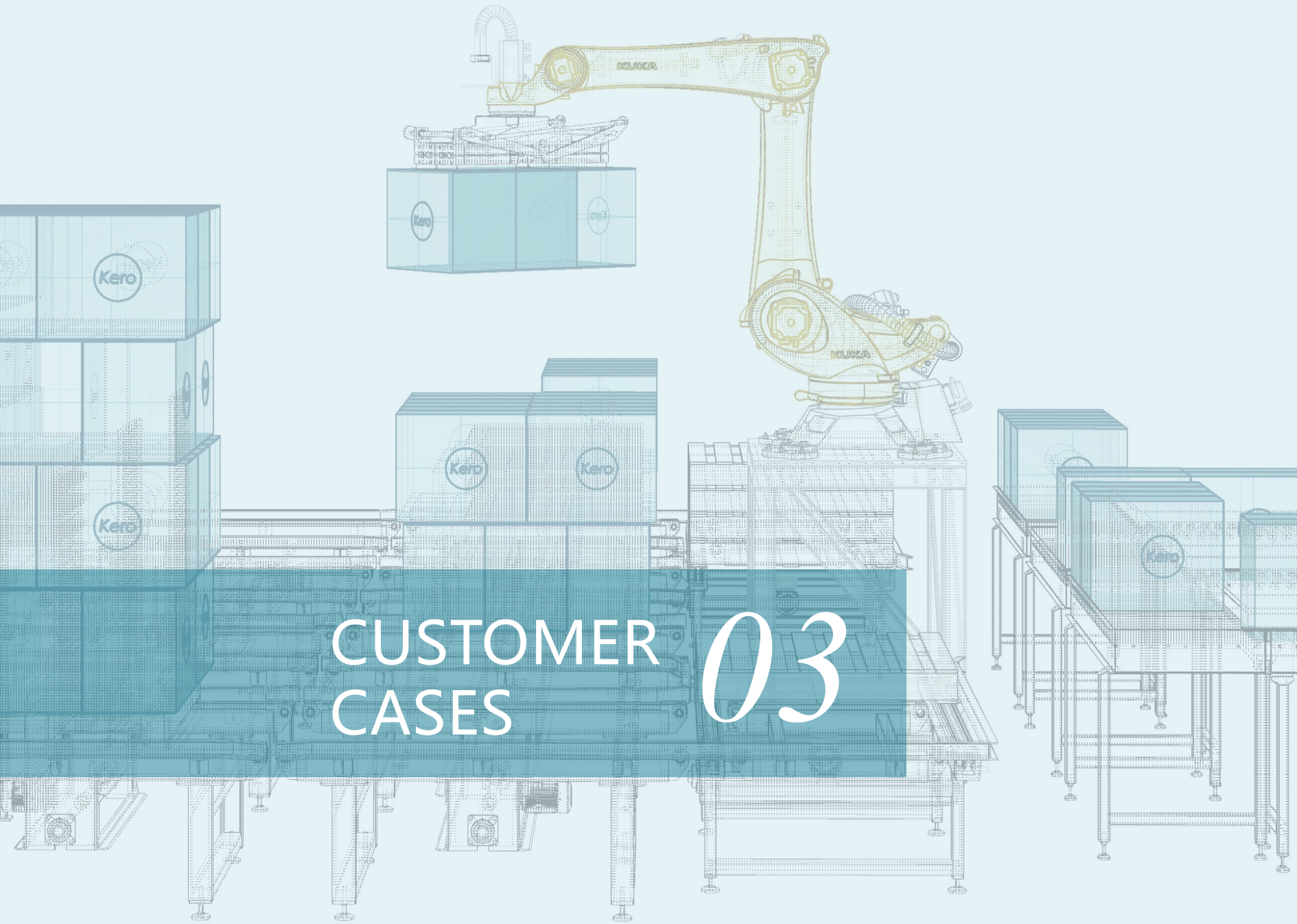

CUSTOMER
CASES 03

Numerical Control Equipment | GSK

Mechatronics design and virtual debugging platform

Robots, processing equipment (maching centers, injection molding machines, etc.)

Definition and control of motion mechanisms such as positioners, conveyor belts, and cylinders

Supports sensor modeling with the built-in library

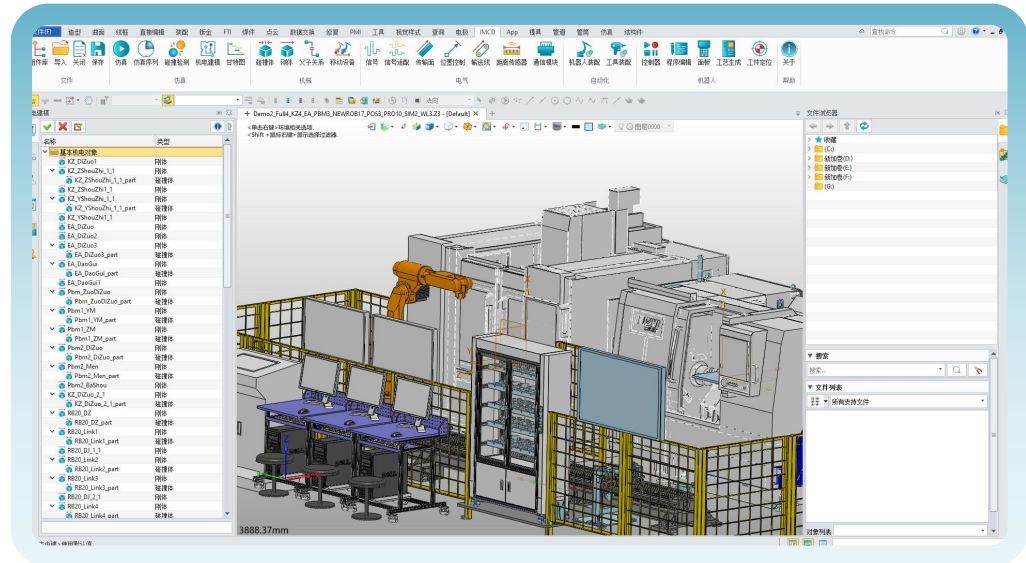

Teaching

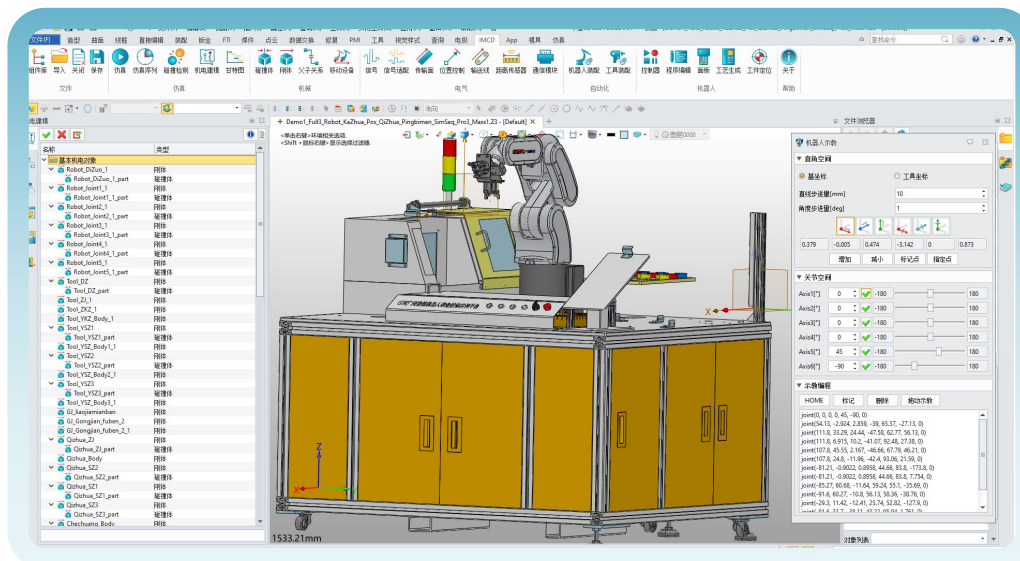

Robot interpolation algorithms, including several basic interpolation algorithms such as straight lines, arcs, joints, etc.

Achieve multiple programming mode selections for industrial robots, such as hand-held tool and hand-held workpiece modes.

Special Equipment Integration | Reference

- Welding and spraying workstation with offline programming and virtual debugging

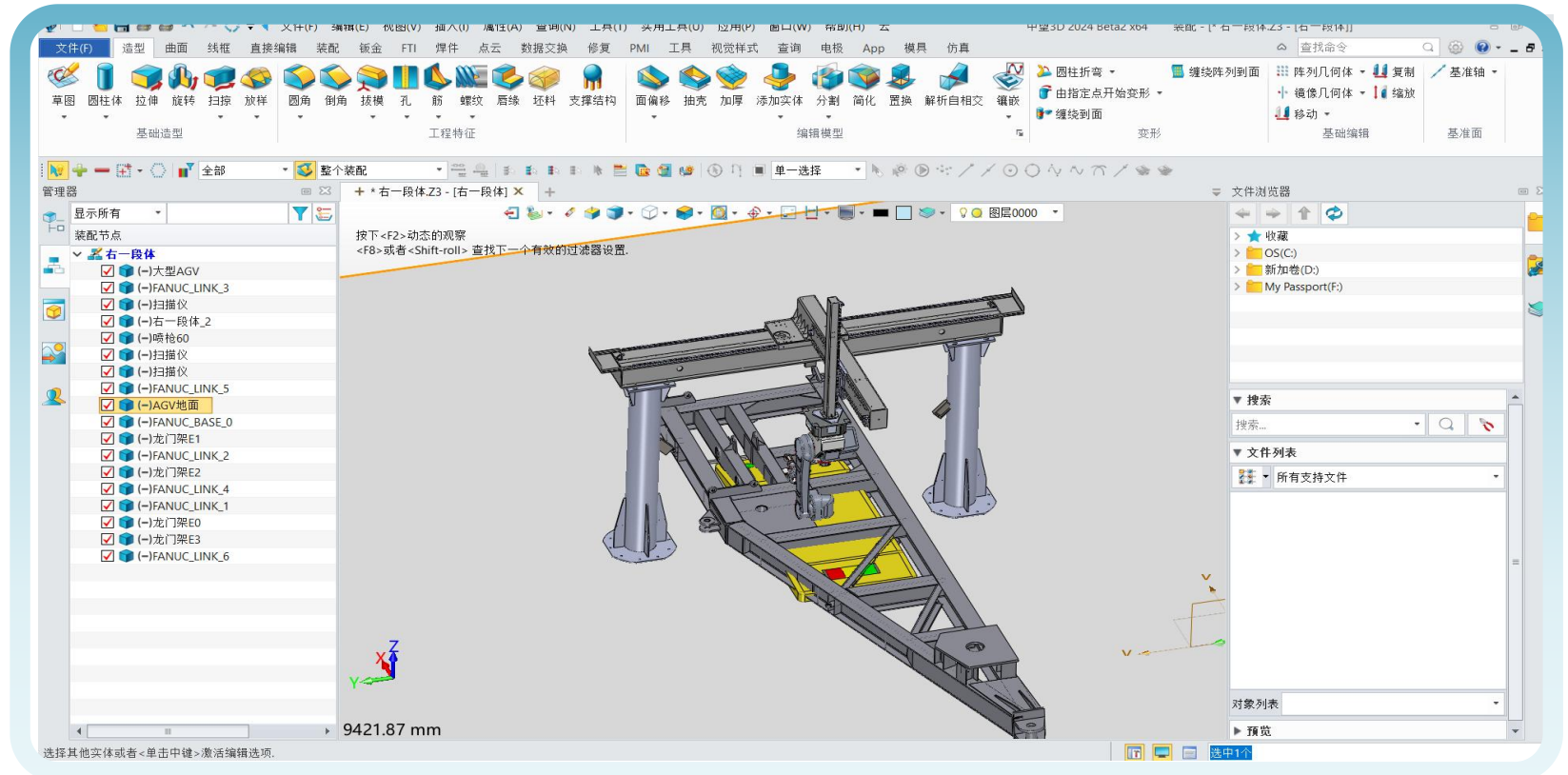
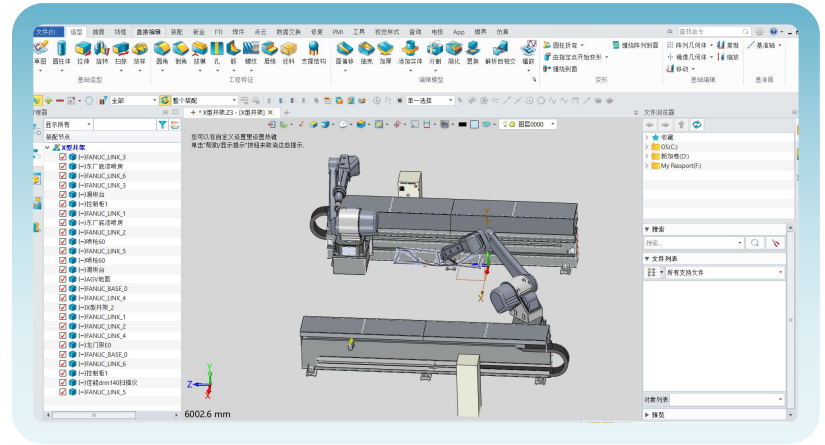
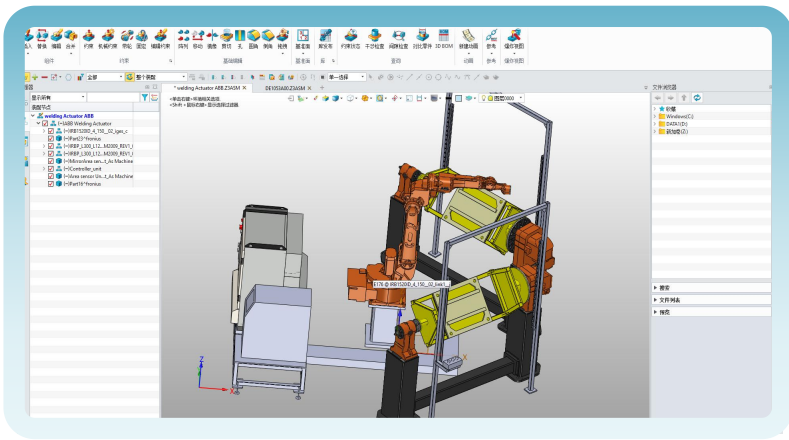

Education equipment

Motor assembly simulation, including robots, quick-change devices, conveyor lines, and various sensors

Digital twin simulation, collect production line data, and map motion controller data and PLC data to the simulation system

System simulation including conveyor lines, multi-robots, and material systems

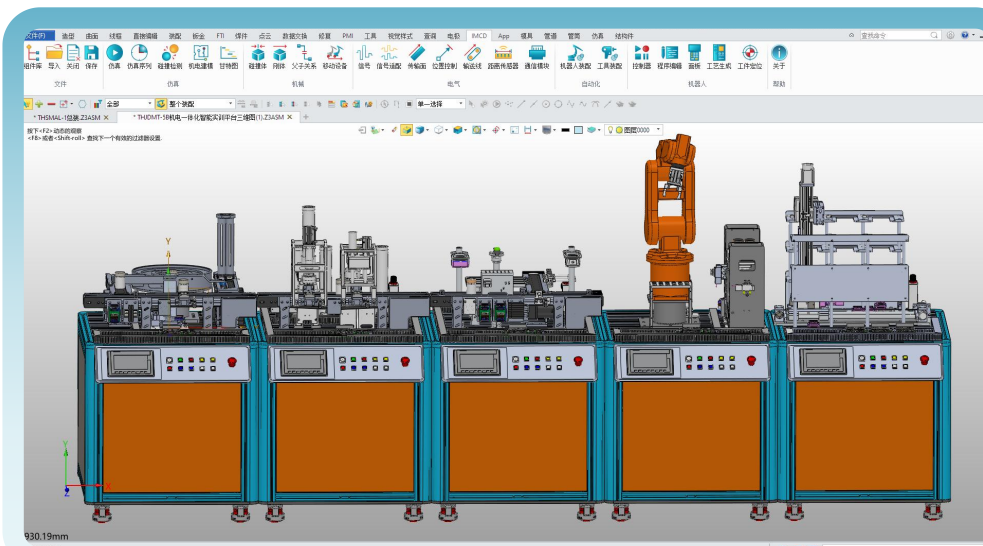
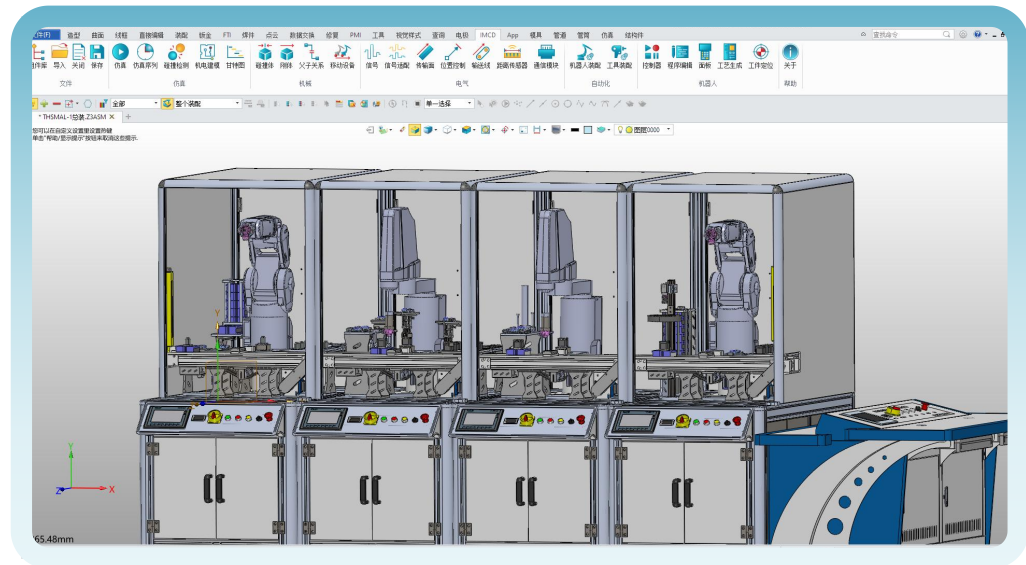

Material packaging simulation, including vibrating plates, multiple conveyor lines, robots, motor drives, material assembly, material transportation, and material warehousing

With data collection, data mapping, materials and motion equipment information, achieve digital-twin virtual debugging in both of hardware and software

南京越擎信息科技有限公司 | Nanjing Yueqing Information Technology Co., Ltd

Address

No. 268, Zhongshan Road,
Xuanwu District, Nanjing City,
Jiangsu Province

Email

cooperation@iRobotCAM.com

Website

www.iRobotCAM.com

